

RACK PROTECTORS

Features and Benefits

- Handle-It™ Heavy Duty Steel Rack Protectors protect rack uprights from powered and non-powered material handling equipment. This product provides a simple, inexpensive solution to the problem of protecting rack structures.
- High-visibility glossy yellow powder coat paint on steel not only protects the Rack Protector from paint chipping, it also offers a visible barrier between forklifts and rack structures. The Handle-It™ Rack Protector is easily installed by anchoring to the concrete floor through holes in the bottom rail of each right-hand or left-hand base angle with standard $\frac{3}{4}$ " diameter wedge anchors (supplied as optional purchase).
- The durable Handle-It™ Rack Protectors, weighing 38 to 70 pounds each, hold up under forklift traffic around the rack structure. Standard sizes are 46" to 53 $\frac{1}{2}$ " overall length to fit around single rack structures 42" or 48" deep with a space between the end of the protector and the end of the rack. If complete enclosure is desired, the Rack Protector Extender (a 48" long matching heavy duty floor angle) can be field cut to the exact length needed.
- Handle-It™ Rack Protectors are constructed of heavy-duty steel floor angles securely welded to durable formed circular steel end pieces. The rounded ends on each right-hand or left-hand protector fit closely around rack corners, taking up minimum aisle space while providing needed protection. Handle-It™ Rack Protectors are useable in warehouses and plants at a broad range of temperatures, including freezers where temperatures are below 0°C.

Medium Duty Rack Protectors

- Handle-It™ Medium Duty Steel Rack Protectors are also available for protecting rack structures from impact from non-powered material handling equipment traffic.
- Medium Duty Rack Protectors have the same paint finish, length, width, height and mounting hole diameters as the Heavy Duty Rack Protectors, but they are lighter in weight (approximately 65% of the weight of Heavy Duty Rack Protectors).
- Medium Duty Rack Protectors should be limited in use to applications involving non-powered material handling equipment.



Left Rack Protector



Right Rack Protector



Dual Rack Protector

Guarantee and Warranty

Personal and professional customer service is offered on all Handle-It™ products. Our Rack Protectors carry a two-year limited warranty on all materials and workmanship.

1-800-236-1080
www.miiequipment.com

RACK PROTECTOR DIMENSIONS

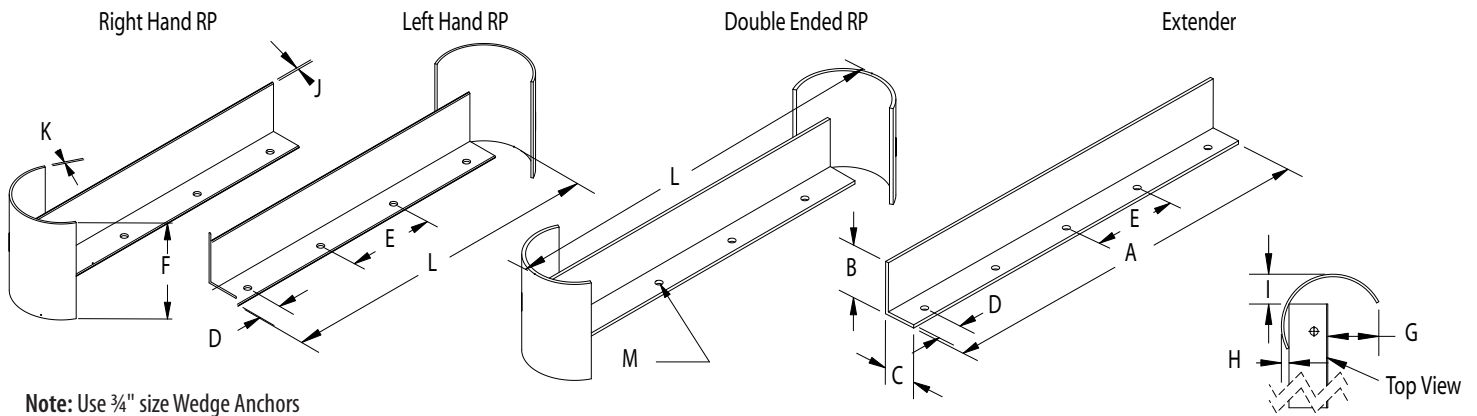

Note: Use 3/4" size Wedge Anchors

Dimensions (Inches)

Part	A	B	C	D	E	F	G	H	I	J	K	L	M	Number of Holes	Curve Location
RP-42LH-MD	43	6.5	4	5.8	10.5	12	5	1	3	0.25	0.25	46	0.85	4	Left
RP-42RH-MD	43	6.5	4	5.8	10.5	12	5	1	3	0.25	0.25	46	0.85	4	Right
RP-48LH-MD	47.5	6.5	4	2.8	10.5	12	5	1	3	0.25	0.25	50.5	0.85	5	Left
RP-48RH-MD	47.5	6.5	4	2.8	10.5	12	5	1	3	0.25	0.25	50.5	0.85	5	Right
RP-36LH-HD	37	6.5	4	2.8	10.5	12	5	1	3	0.4	0.4	40	0.85	4	Left
RP-36RH-HD	37	6.5	4	2.8	10.5	12	5	1	3	0.4	0.4	40	0.85	4	Right
RP-42LH-HD	43	6.5	4	5.8	10.5	12	5	1	3	0.4	0.4	46	0.85	4	Left
RP-42RH-HD	43	6.5	4	5.8	10.5	12	5	1	3	0.4	0.4	46	0.85	4	Right
RP-42EX-HD	43	6.5	4	5.8	10.5	N/A	N/A	N/A	N/A	0.4	N/A	43	0.85	4	No Curve
RP-48LH-HD	47.5	6.5	4	2.8	10.5	12	5	1	3	0.4	0.4	50.5	0.85	5	Left
RP-48RH-HD	47.5	6.5	4	2.8	10.5	12	5	1	3	0.4	0.4	50.5	0.85	5	Right
RP-48EX-HD	47.5	6.5	4	2.8	10.5	N/A	N/A	N/A	N/A	0.4	N/A	47.5	0.85	5	No Curve
RP-62EX-HD	62	6.5	4	4.8	10.5	N/A	N/A	N/A	N/A	0.4	N/A	62	0.85	6	No Curve
RP-36-HD	37	6.5	4	2.8	10.5	12	5	1	3	0.4	0.4	43	0.85	4	Both Sides
RP-42-HD	43	6.5	4	5.8	10.5	12	5	1	3	0.4	0.4	49	0.85	4	Both Sides
RP-48-HD	47.5	6.5	4	2.8	10.5	12	5	1	3	0.4	0.4	53.5	0.85	5	Both Sides
RP-108-HD	109	6.5	4	7.4	10.5	12	5	1	3	0.4	0.4	115	0.85	10	Both Sides

Custom sizes and lengths are available. Please consult factory.

Rack Protector Equipment Specification

To ensure proper protection consider the following:

- Measure overall length of area that is to be protected.
- Is there a protruding object or other unusual configuration to measure? (Going around corners)
- Is this a single or double end application? (Exposure to traffic is the key factor.)
- Place protection equipment as close as possible while still providing an adequate barrier in front of what you're protecting to achieve proper installation.