



H-HD Hydraulic Pit Leveler

www.miiequipment.com

Hydraulic: 1HP, 1GPM

25,000; 30,000, 35,000; 40,000; and 45,000 lbs. dynamic capacities are available in 6', 6.5', and 7' widths by 6', 8', and 10' lengths.



**Dependable
Handle-It Levelers Keep
Working for You!**

Handle-It H-HD Series Hydraulic Pit Levelers offer strength and easy operation. A single rotary switch control activates and recycles the leveler when the truck is at the dock or departing. The hydraulic system provides smooth and efficient operation. The Deck and lip are constructed of 55,000 lbs. minimum yield steel tread plate. The Lip Keepers sever to provide for safe cross traffic when the unit is stored and night locks for added security. Each Handle-It H-HD Series Pit Leveler comes with dock bumpers and grease fittings on the lip hinge.



Warranty

Handle-It offers a 1-year warranty on all parts including structural members, motor pump, and miscellaneous parts (including materials, labor, and freight).

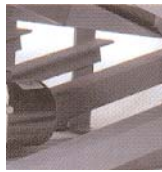

Exclusive Handle-It Base Frame Support Struts make our H-HD Series the strongest and safest in the industry!



Solid Steel Structural "C" Channel offers matchless deck support - providing a 39% greater resistance to elastic bending than other designs.



Inline Safety Stop guards against leveler free-fall in the event of premature truck departure.



Guarantee

Handle-It will provide our standard warranty **or match any documented competitive warranty in the industry** for comparable models. There is no fine print. *We guarantee it!*



HANDLE-IT
M I I E Q U I P M E N T

HYDRAULIC PIT LEVELER PIT DETAIL

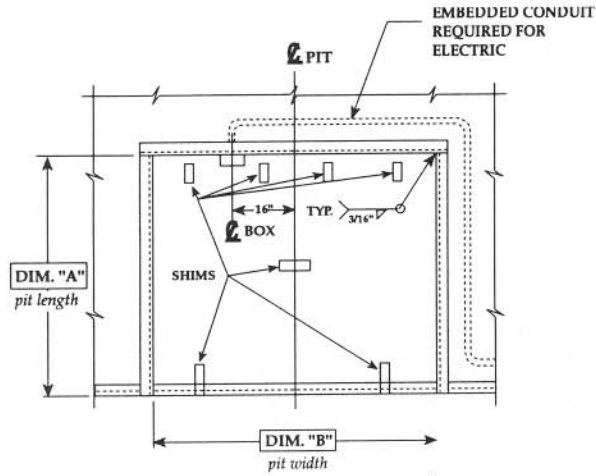

VARIABLE DIMENSIONS				
MODEL SIZE	"A"	"B"	"C"	"D"
6'W X 6'L	63"	74"	19 1/2"	20"
6'W X 8'L	87"	74"	19 1/2"	20"
6'W X 10'L	111"	74"	23 1/2"	24"
6 1/2'W X 6'L	63"	80"	19 1/2"	20"
6 1/2'W X 8'L	87"	80"	19 1/2"	20"
6 1/2'W X 10'L	111"	80"	23 1/2"	24"
7'W X 6'L	63"	85"	19 1/2"	20"
7'W X 8'L	87"	85"	19 1/2"	20"
7'W X 10'L	111"	85"	23 1/2"	24"

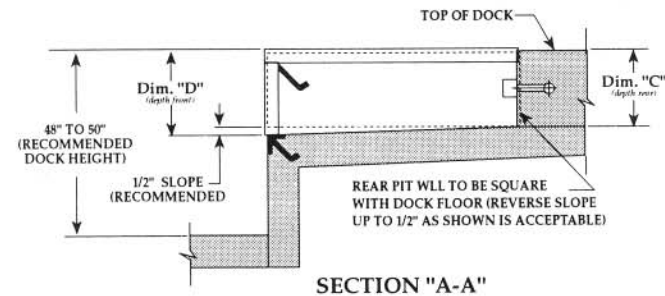
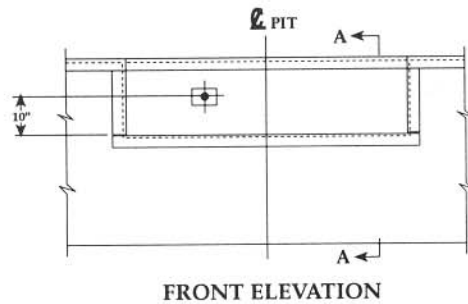
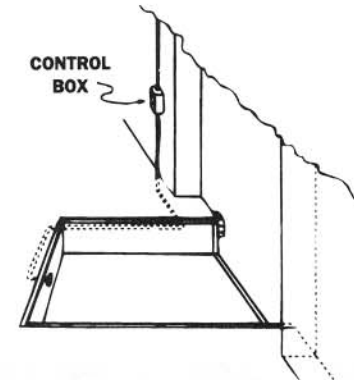

H-MD Mechanical Pit Leveler

H-MD Series

20,000; 25,000; 30,000; 35,000; 40,000;
and 45,000 lb Dynamic
Capacities (Larger Capacities Available)

6', 6'6", and 7' Widths
6', 8' and 10' Lengths
(Custom Sizes Available)



■ Dependable HANDLE-IT Levelers Keep Working For You.

Offering a variety of dynamic capacities, the H-MD Series Leveler provides 18" and 20" lip options, in addition to many other custom features. Dual 60,000 lb safety legs provide additional strength and support. Deck and lip are constructed of 55,000 lb minimum yield steel tread plate. Lip keepers serve as night locks for security and provide safe cross-traffic support when unit is stored. Dock bumpers are grease fittings on lip hinge are standard with each unit

■ Warranty

HANDLE-IT offers a 1-year warranty on all parts including structural members, main springs, and mechanical and miscellaneous parts (including materials, labor, and freight).

■ Guarantee

Handle-It will provide our standard warranty or **match any documented competitive warranty in the industry** for comparable models. There is no fine print. *We guarantee it!*



HANDLE-IT's solid steel **Structural "C" Channel** offers matchless deck support - providing a 39% greater resistance to elastic bending moments than other industry designs



Positive Hold-down Device allows up and down float when in service



Fully mechanical, single-handed **Pull-chain Operation** means **NO LIFTING** or **STRAINING**.



The H-MD's simple, **Direct Extension Spring Design** has no moving parts - nothing to service



HANDLE-IT
M I I E Q U I P M E N T

MECHANICAL PIT LEVELER PIT DETAIL

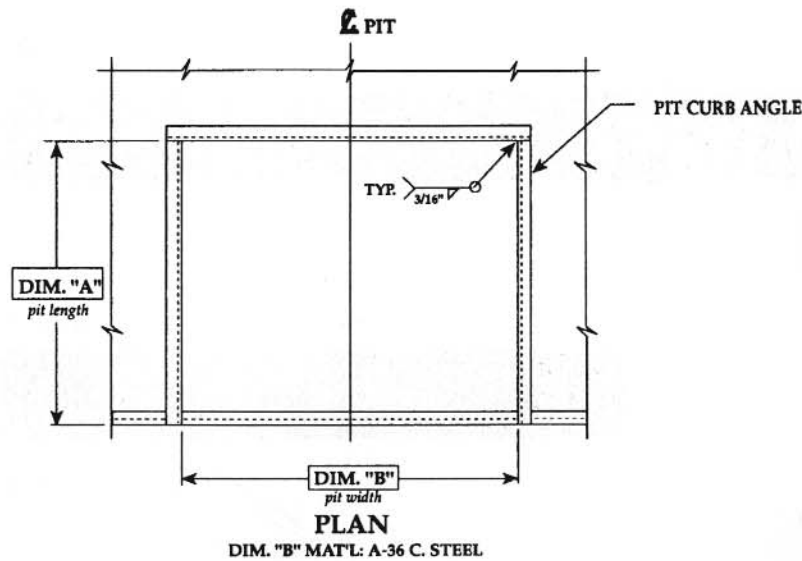

VARIABLE DIMENSIONS				
MODEL SIZE	"A"	"B"	"C"	"D"
6'W x 6'L	63"	74"	19½"	20"
6'W x 8'L	87"	74"	19½"	20"
6'-6"W x 6'L	63"	80"	19½"	20"
6'-6"W x 8'L	87"	80"	19½"	20"
7'W x 6'L	63"	85"	19½"	20"
7'W x 8'L	87"	85"	19½"	20"
6'W x 10'L	111"	74"	23½"	24"
6'-6"W x 10'L	111"	80"	23½"	24"
7'W x 10'L	111"	85"	23½"	24"

