



12247 W FAIRVIEW AVE • MILWAUKEE, WI 53226 • PH(800)236-1080 • FAX (414)453-9975

SWM-SA-1100AA-C

Max Capacity: 4400 lbs

Max Volume: 300 Pallets/Day

Weight: 1300 lbs

Film Spec: 20" 70 ga Machine Film
w/ 3" Core

Additional

Requirements: 90 psi min. Air Supply
[8 gal. min Compressor
Recommended]

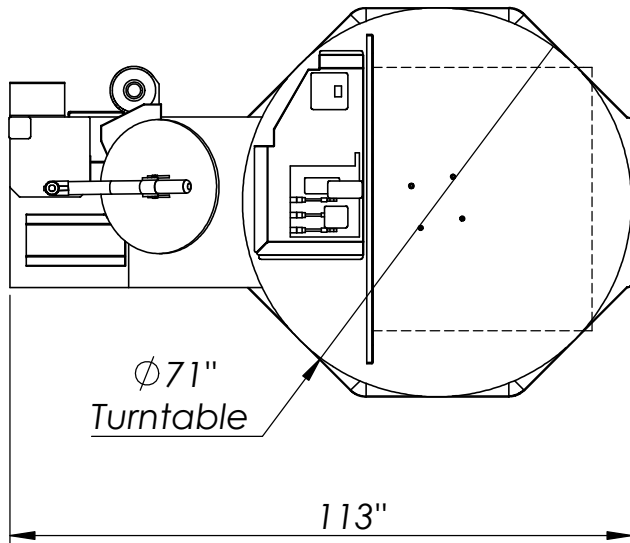

Integrated Scale Option:
Weighs Pallet Loaded on Machine
Adds 2.75" To OAH

Extended Height Option:
Increases Wrap Height to 118"

