



Low-Profile Semi-Automatic Stretch Wrap Machine

**HANDLE-IT® SA Series**

# Model 850PS

**Full Set of Functions and Options**

**250% Power Pre-Stretch Carriage**

**100 Max Average Pallets Per Day!**

**3 YEAR WARRANTY**



Part Number  
SWM-SA-0850PS

## Handle-It® Model 850PS

The Handle-It® Model 850PS offers top-of-the-line functions and features at a great price. It is ideal for those who are looking for an efficient machine capable of handling moderate to high volumes of pallets per day. It comes standard with a 250% powered pre-stretch carriage to maximize your film usage.

### Technical Specifications

Wrap Height	86"
Turntable Diameter	59"
Max Pallet Size	48" x 80" (93" Diagonal)
Turntable Height	3"
Weight Capacity	4,400 lbs
Pre-Stretch	250% Powered
Power Supply	110V, 10 Amp
Total Machine Footprint	93" long x 60" wide
Machine Weight	600 lbs
Turntable Speed	13 RPM

# Handle-It® Semi-Automatic Stretch Wrapper

## Product Specifications

- Frequency controller for turntable speed adjustment (from 3 to 13 RPM)
- Frequency controller for carriage speed adjustment (speed going up and speed going down can be set differently)
- Powered film pre-stretch for up to 250% film efficiency
- Photocell for pallet height detection with photo eye delay
- Safety stop at the base of the carriage
- Stop at 0 position
- 2 access keys (including lock mode)
- Many parameters available at upper password level
- Reinforcing operation
- 3 working cycles: ascent/descent; topsheet; only ascent
- 9 wrap programs can be saved by the customer
- 9 additional recordable playback cycles can be saved
- 3 year warranty



### Adjustable parameters by the control panel:

cycle selection, bottom turns, top turns, rotation speed, carriage speed going up, carriage speed going down, film tension.



### Powered pre-stretch film carriage (250%)

for greatly improved film efficiency.

## Available Options

- Integrated Scale
- Loading Ramp
- Photocell for Dark Loads
- Extended height: 98"
- Forklift wheel stop
- Guarding



Integrated Scale



Forklift Wheel Stop



Ramp

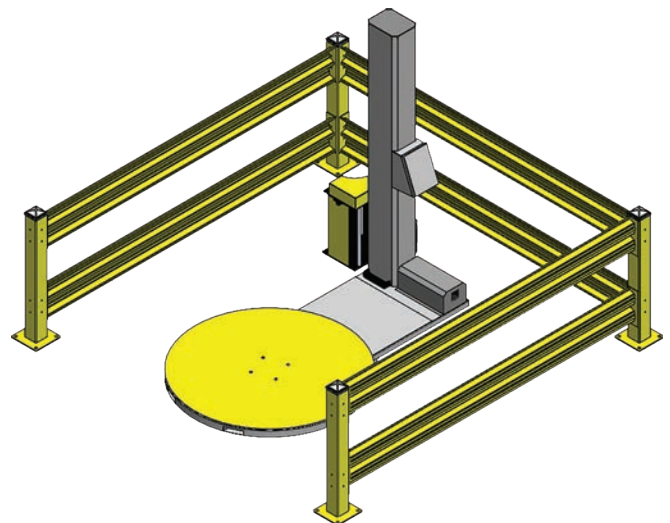

3-Sided Guard Rail Package