

The Handle-It® Model 1200UL offers top-of-the line functions and features at a great price. Designed to save you the most floor space of any turntable style machine w/ramp combo in the industry. Easily load/unload with:

Manual Pallet Jacks | Electric Pallet Jacks | Forklifts



**Patented Ultra Low Frame
Less Than ¾" From the Floor!**

250% Power Pre-Stretch Carriage

Up to 35 Pallets Per Hour!

TECHNICAL SPECIFICATIONS

Wrap Height	94" Max
Turntable Diameter	66"
Max Pallet Size	40" x 48" (66" diagonal)
Turntable Height	Less than ¾" (0.71")
Weight Capacity	2,600 lbs.
Pre-Stretch	250% Powered
Power Supply	110V, 10 Amp
*Total Machine Footprint	119" Long x 82" Wide x 95" Height
Machine Weight	1200 lbs
Turntable Speed	12 RPM

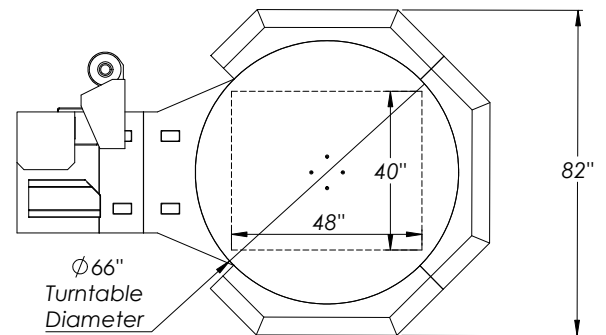
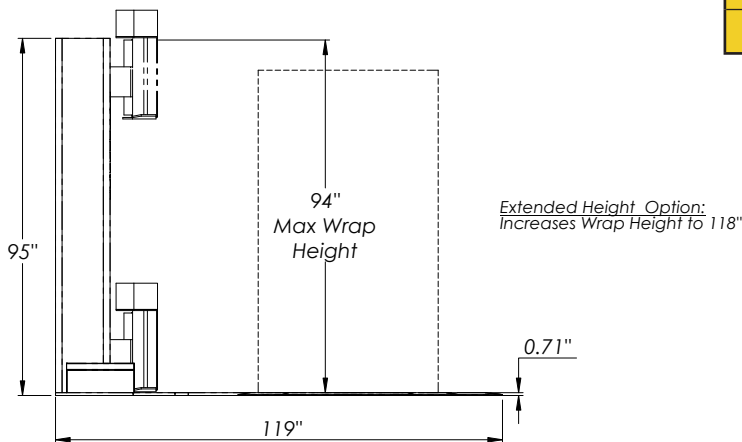

*Footprint includes 3-sided ramp

PRODUCT SPECIFICATIONS

- Photocell for pallet height detection with photo eye delay
- Variable film tension
- Safety stop at base of carriage
- Adjustable carriage up and down speed
- Reinforcement wrap settings
- Wrapped pallet counter
- Brushless AC motors
- On-board diagnostics
- Stop at home position
- 3 year warranty
- 20" Carriage



Digitally Controlled Power Film Pre-Stretch

for dynamically controlled film efficiency and improved load containment, both lowering consumable cost and keeping your product safe and secure



Responsive and User Friendly PLC Controls:

- Fully customized wrap cycles
- Up to 32 programmable cycle recipes
- 6 quick select buttons for quick navigation
- Over 50 different parameters with variable film tension and speed controls
- USB port allows upload and download of data with statistic reporting and system diagnostics



Patented Ultra Low Frame

- Easier and safer to load with any equipment
- Eliminates space eating 5' loading ramps
- Easily transition load from three sides

AVAILABLE OPTIONS

- Auto Film Cut
- 118" Height Extension
- Automatic Roping System
- Top Press
- Photocell for Dark Loads
- Cold Environment Kit
- Remote Control
- Film Usage Diagnostics
- 30" Carriage
- Anti-static Brush
- Window & Door Kit
- Light Curtains